

A1

DO NOT SCALE

File: 5158632_HTR_DR_02_0113.dwg
Date: Jun 15, 2022 - 4:55pm
Plotted by: yomacho



- GENERAL NOTES**
1. ALL DIMENSIONS ARE IN MILLIMETRES UNLESS NOTED OTHERWISE
 2. ONLY WRITTEN DIMENSIONS SHALL BE USED. NO DIMENSIONS SHALL BE SCALED FROM THE DRAWINGS
 3. ALL LEVELS ARE IN METRES AND ARE TO MALIN HEAD DATUM
 4. ALL COORDINATES ARE IN METRES AND ARE TO IRISH TRANSVERSE MERCATOR
 5. DRAWINGS ARE TO BE READ IN CONJUNCTION WITH THE SPECIFICATION

- LEGEND:**
- SITE BOUNDARY
 - LANDS IN OWNERSHIP OF THE APPLICANT
 - PROPOSED NATURAL WALL
 - PROPOSED FOOTPATH
 - PROPOSED CARRIAGEWAY
 - PROPOSED SHARE SURFACE TREATMENT
 - UNCONTROLLED PEDESTRIAN CROSSING
 - PROPOSED RAISED TABLE AT JUNCTIONS
 - PROPOSED RAISED TABLE
 - PROPOSED SURFACE BEIGE ROAD
 - PROPOSED PARKING SPACES
 - CYCLE PARKING - BIN AREA
 - SHEFFIELD STAND CYCLE PARKING
 - PROPOSED SUBSTATION
 - PROPOSED LANDSCAPE AREA (REFER TO LANDSCAPE DRAWING)
 - PROPOSED ROAD SIGN

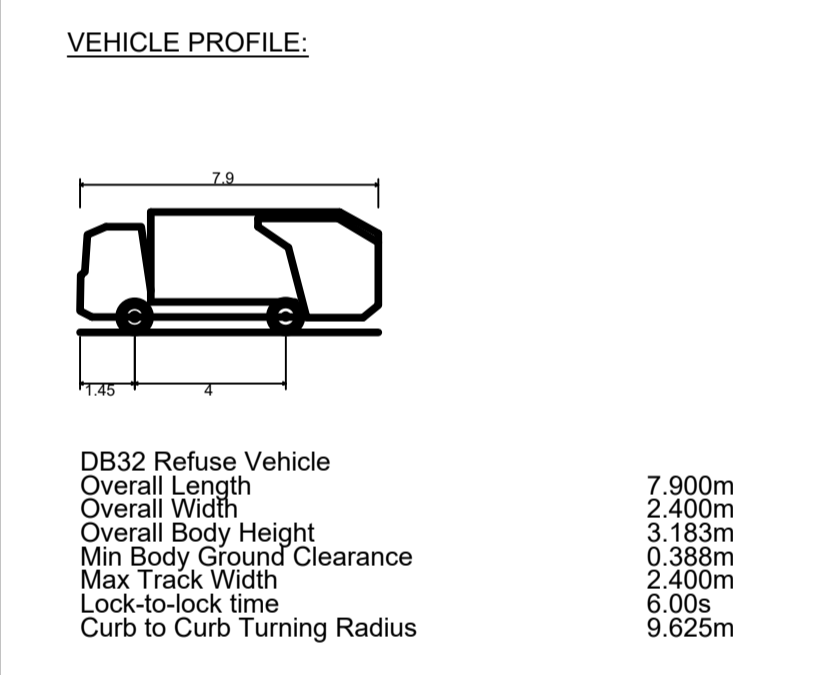

© ORDNANCE SURVEY IRELAND LICENSE NR. AR 0082521. ORDNANCE SURVEY IRELAND & GOVERNMENT OF IRELAND

ATKINS WILL NOT TO BE HELD LIABLE FOR THE USE OF THIS DATA ON ANY PROJECT OTHER THAN THE PROJECT:
LANDS AT WAYSIDE KILTERNAN DUBLIN 18

Risk Level	X	Atkins Base Line - Low Risk
		Atkins Sensitive - Medium Risk
		Atkins Private - High Risk
		Client Critical - Already Marked

Rev	Description	By	Date	Chk'd	Rev'd	Auth
1	PLANNING	YC	13.06.22	PF	PF	KB
0	PLANNING	YC	09.05.22	PF	PF	KB

<p>ATKINS Member of the SNC-Lavalin Group</p> <p>Atkins House, 150-155 Ainslie Business Park, Swords, Co. Dublin Tel (+353) 01 810 8000 Fax (+353) 01 810 8001</p> <p>Unit 2B, 2200 Cork Airport Business Park, Cork Tel (+353) 021 429 0300 Fax (+353) 021 429 0360</p> <p>1st Floor Technology House Parkmore Technology Park, Galway Tel (+353) 091 786 050 Fax (+353) 091 779 830</p>	
---	--

Client	LISCOVE LIMITED
Project	LANDS AT WAYSIDE KILTERNAN DUBLIN 18

Purpose	PLANNING
Title	KILTERNAN VILLAGE SHD REFUSE - VEHICLE TRACKING SHEET 2 OF 2
Original Scale	1:500 at A1
Drawn	YC
Checked	PF
Reviewed	PF
Authorised	KB
Date	09.05.22
Date	09.05.22
Date	09.05.22
Date	09.05.22
Status	P
Drawing Number	5158632 / HTR / DR / 02 / 0113
Rev	1